

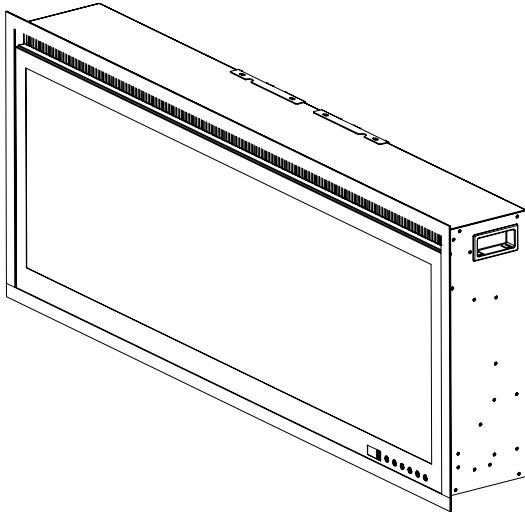

KALORA

NEXUS ELECTRIC FIREPLACE OPERATION AND INSTALLATION MANUAL



KALORA NEXUS

36" Electric Fire SGO10100039

50" Electric Fire SGO10100040

60" Electric Fire SGO10100041

74" Electric Fire SGO10100042

Kalora Pty Ltd

Head Office
58 Access Way
Carrum Downs VIC 3201
Australia

+61 3 8579 5900
info@kalora.com.au
www.kalora.com.au



Nex Version 1.0.2 24/01/2024

Contents of this manual may be updated without notice.

Model Name	Model Number
Nexus 36"	SG010100039
Nexus 50"	SG010100040
Nexus 60"	SG010100041
Nexus 74"	SG010100042

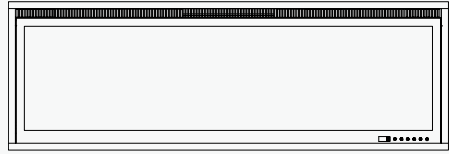

Specifications

Model	Nexus 36"	Nexus 50"	Nexus 60"	Nexus 74"	
Rated Power	1500W				
Rated Voltage	240V ~ 50Hz				
Appliance Dimensions	Height	429 mm	429 mm	429 mm	429 mm
	Width	915 mm	1270 mm	1510 mm	1880 mm
	Depth	150 mm	150 mm	150 mm	150 mm
Unit Net Weight	18.4 KG	21.6 KG	26.5KG	30.5 KG	
Installation Options	Recessed or Wall				
Power cable length	1.8m				
Power cable position	Right hand rear corner				



WARNING

This appliance must be installed in accordance with:

- Manufacturer's Installation Instructions
- Current AS/NZS 3000
- Local Regulations and Municipal Building Codes

Including local OH&S requirements. For continued safety of this appliance it must be installed and maintained in accordance with the manufacturer's instructions.

CONTENTS

Introduction	3
Recessed Wall Installation	4
Wall Mounted Installation	7
Operation	10
Care And Maintenance	13
Warranty	14

INTRODUCTION

Congratulations on purchasing a genuine Kalora Electric Fireplace. When cared for properly, these high quality, finely crafted appliances will offer many years of reliable performance. This instruction manual has been developed to ensure optimum performance from your Kalora Electric Fireplace. It's very important that you thoroughly read and understand all instructions before using your new appliance.

IMPORTANT INSTRUCTIONS

When using electrical appliances the following precautions should always be followed to reduce the risk of fire, electric shock or injury to persons:

- 1 Read all instructions before using this appliance.

- 2 The appliance maybe hot when in use. To avoid burning, do not touch hot surfaces. Keep combustible items, such as furniture, pillows, bedding, papers, clothes, and curtains at least 1m from the hot air outlet of the appliance.

- 3 Extreme caution is necessary when any appliance is used near children or infants.

- 4 Do not operate the appliance with a damaged cord or plug or when it has been dropped or damaged in any manner, instead return the appliance to place of purchase.

- 5 Do not use this appliance outdoors.

- 6 This appliance is not intended for use in bathrooms or laundry areas.

- 7 If you need to disconnect the appliance, turn controls to off, then remove plug from outlet.

- 8 Do not inset or allow foreign objects to enter any inlet or outlet vents as this may damage the appliance.

- 9 To prevent damage to the appliance, do not block air inlets or the heating outlet.

- 10 Do not operate this appliance using a powerboard or extension leads.

- 11 Use this appliance only as describes in this manual. Any other use is not recommended by the manufacturer.

- 12 Never cover or partially cover the appliance during use.

- 13 This appliance is not intended for use by persons (including children) with reduced physical, sensory or capabilities, or lack of experience and knowledge, unless they have been given supervision or instruction concerning use of the appliance by a person responsible for their safety.Children should be supervised to ensure that they do not play with the appliance.

- 14 Never operate this appliance using an external switching device, such as a timer or remotely switched circuit.

UNPACKING THE APPLIANCE

Carefully remove the appliance from the box and check all items are present and inspect for any physical damage to the appliance, accessories, power cord and plug. Prior to installing the appliance, test to make sure the appliance operates properly by plugging the power cord into a conveniently located and grounded GPO.

RECESSED WALL INSTALLATION

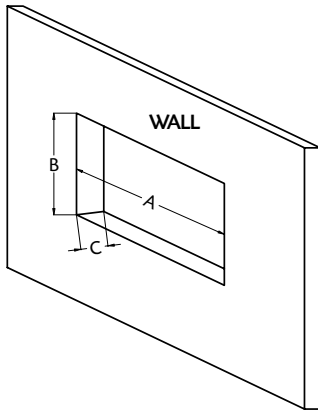

WALL CAVITY DIMENSIONS

Model	A (Width)	B (Height)	C (Depth)
Nexus 36"	890	410	160
Nexus 50"	1245	410	160
Nexus 60"	1510	410	160
Nexus 74"	1855	410	160



WARNING:

Find a suitable location to build the cavity for the fireplace. Minimum clearance from the the mantel is 200mm; the installation location must be near a GPO. Do not locate the appliance immediately below a GPO.

1. "Remove the four silver colored screws on the top of the appliance and take off the wall bracket (See Step 1).

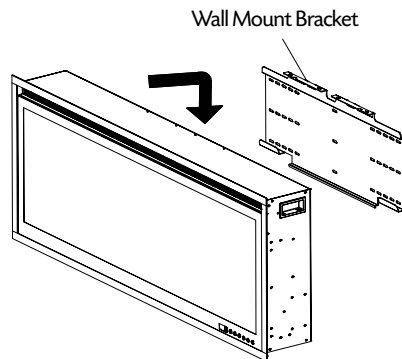
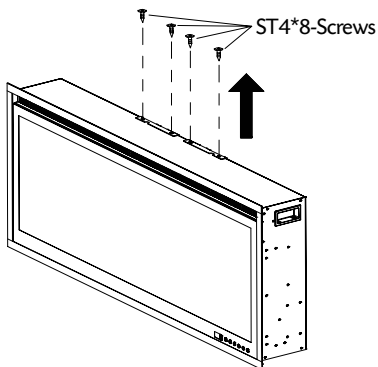

Step 1

RECESSED WALL INSTALLATION...continued

2. To remove the glass, unscrew the 2 silver screws on the left and right hand sides of the appliance. Remove the glass front using the suction lifter provided, move the glass upwards and then outwards (Step 2).

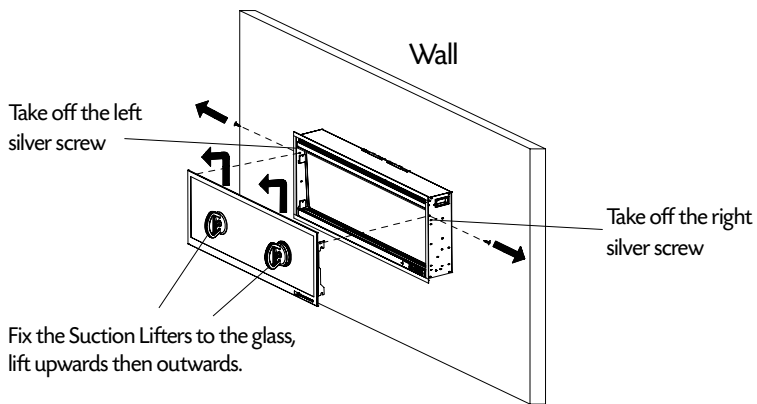

Step 2

3. Before positioning the appliance into the cavity, connect the plug to the GPO, move the appliance into the cavity then fix the 2 silver screws from the inside of the appliance into the cavity wall (See Step 3).

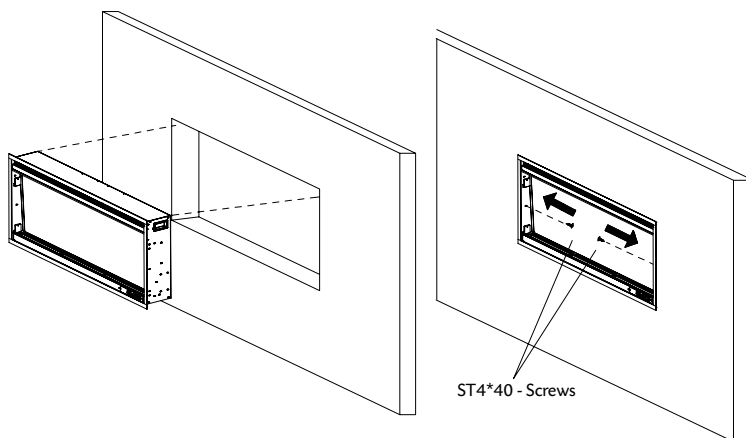

Step 3

RECESSED WALL INSTALLATION...continued

4. Position the plastic base tray as shown, place the crystals and wood fire logs into position (See Step 4)

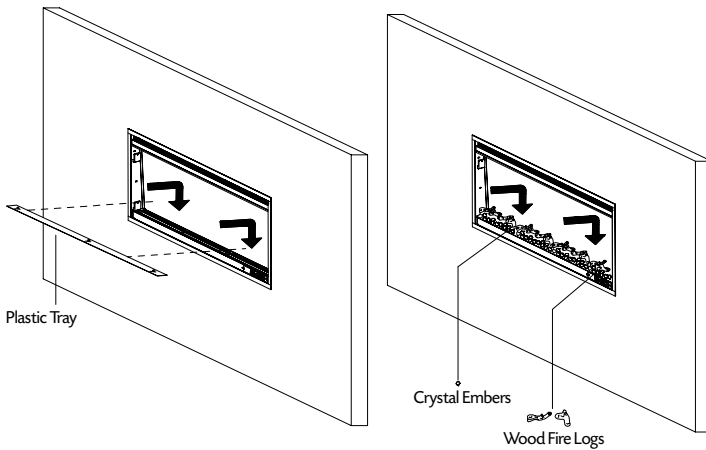

Step 4



WARNING:

ALWAYS use extreme caution when handling glass. Failure to do so could result in personal injury or property damage. Two suction lifters are provided to handle the glass front safely.

5. Install the glass in the direction of the arrows, once securely in place remove the suction lifter.

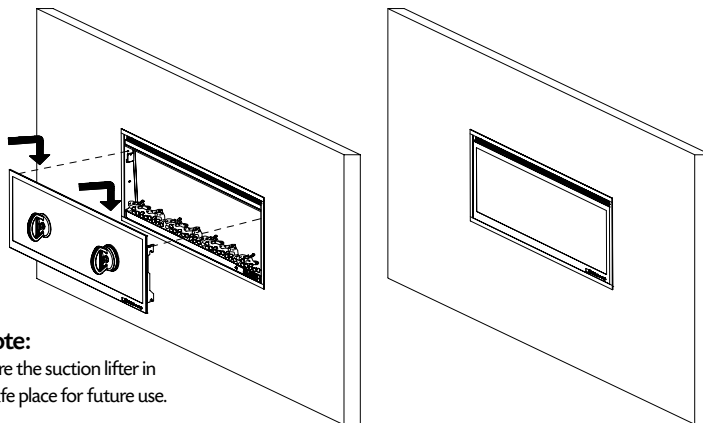

Step 5

WALL MOUNTED INSTALLATION

1. Remove the four silver colored screws on the top of the appliance and take off the wall bracket (See Step 1).

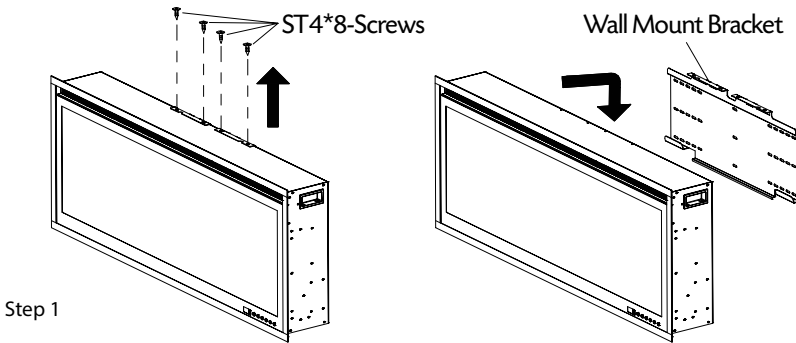

Locate structural members behind the wall and mark out using the wall bracket (See Step 2).

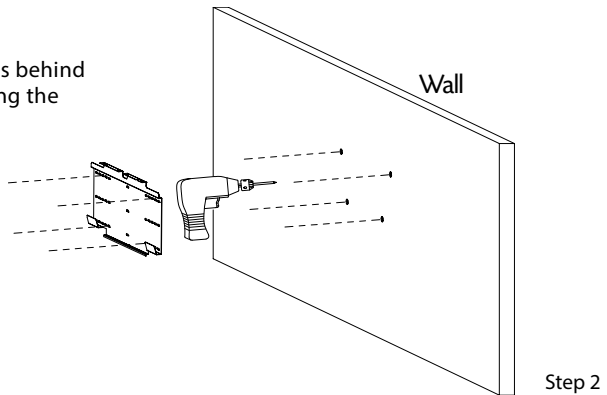

Screw the wall bracket into place (See Step 3).

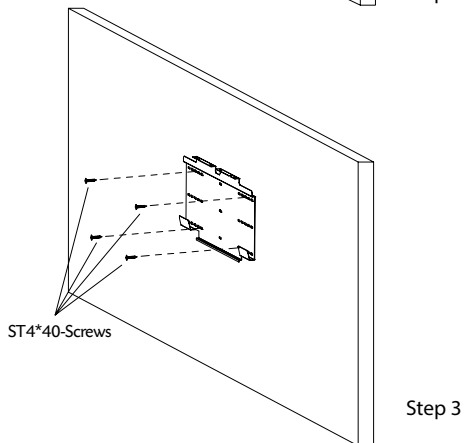

WALL MOUNTED INSTALLATION....continued

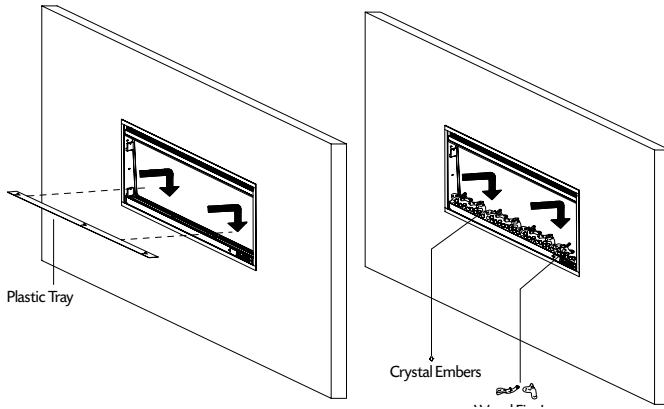

Step 4

2. Lift fireplace and place onto the bracket, fix the 4 silver screws back to the top (Step 4).

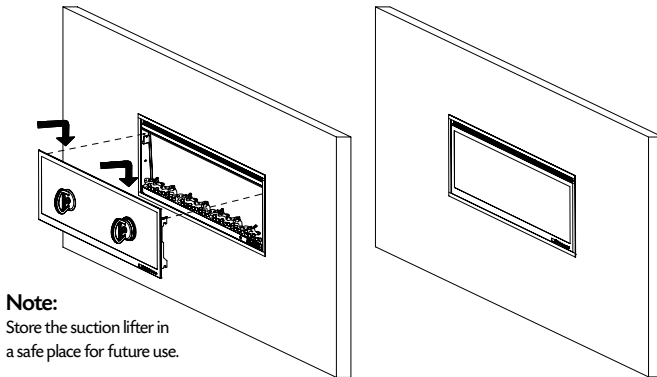

Step 5

WALL MOUNTED INSTALLATION....continued

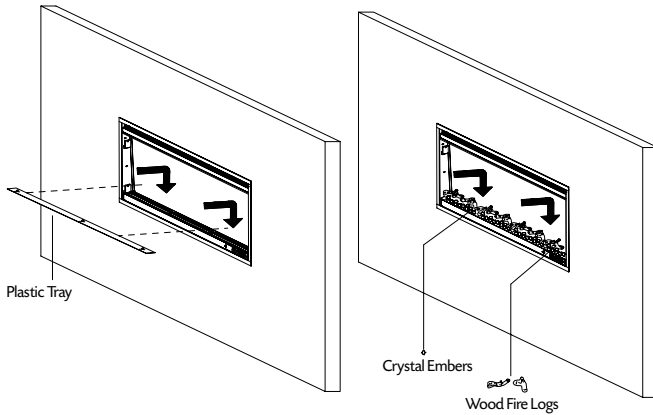

Step 6

3. To remove the glass, unscrew the 2 silver screws on the left and right hand sides of the appliance. Remove the glass front using the suction lifters provided, move the glass upwards and then outwards (Step 5). Remove the glass in the direction of the arrows, using the suction lifter provided.
4. Position the plastic base tray and place the crystals and wood fire logs into position (Step 6).
5. Install the glass in the direction of the arrows, once securely in place remove the suction lifter.

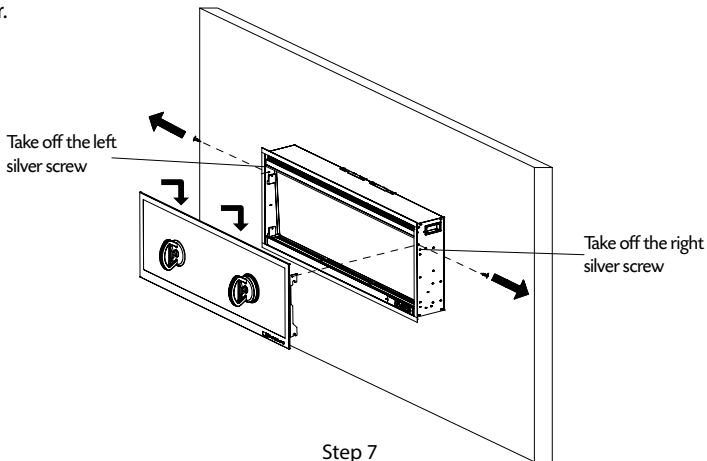

Step 7

- Take care when installing the glass panel. Installing the glass front requires 2 people.
- Carefully set the left and right hand hooks of the glass front inner onto the corresponding left and right hand locating tabs of the firebox.

Make sure the glass is correctly attached to the firebox on both sides. Also ensure the control panel springs are located correctly and not mis-aligned

OPERATION

SAFETY INSTRUCTIONS

- 1 Only use this appliance in accordance with the instructions in this manual.

- 2 Be cautious when handling and disposing of the packaging. The packaging contains plastic wrapping that may be lethal to children.

- 3 Never operate this appliance using an external switching device, such as a timer or remotely switched circuit.

- 4 The appliance is only suitable for indoor use.

- 5 Never use the appliance in the bathroom, shower or near a swimming pool.

- 6 Never leave infants or small children unattended near the appliance.

- 7 In case of a faulty appliance, disconnect the plug immediately and return to the original point of purchase.

OPERATING THE FIREPLACE

Ensure the appliance is plugged into the GPO and switched on. The Control Switch Panel is on the bottom of fireplace (See image below)

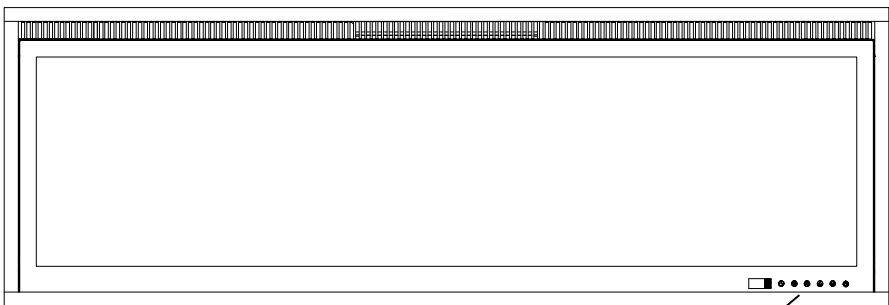

Touch Control Switch Panel

OPERATION....continued

REMOTE CONTROL FUNCTIONS



- This remote control uses two AAA batteries (Included).
- Instructions for battery installation are on the Remote Control battery compartment.

ICON FUNCTIONS

POWER		Turns the appliance ON/OFF.
FLAME		Controls flame effect. 13 colors : (L01,L02...L12,L13)
FLAME LOG		Controls flame log effect. 13 colors : (C01,C02...C12,C13)
TOP LIGHT		Controls Top light colors. 3 colors : (F0 OFF-F1 yellow-F2 blue-F3 purple)
HEATER		Controls the heater function Press button to initiate the heater. (OFF) no heater or fan. (LO), heater fan warm air (750W) (HI), heater fan hot air (1500W) NOTE: Heater functions cycle from OFF-LO-HI
Control with Smart Phone App		You can operate the Nexus Electric Fireplace series with a smartphone App. Use the "Flame" button to pair devices. Scan the QR code below for App Operation Instructions
TIMER		Controls the Timer. 9 Settings: (1h, 2h, 3h, 4h, 5h, 6h, 7h, 8h,9h) Press button until reach desired setting.



WARNING:

NEVER dispose of batteries in fire. Failure to observe this precaution may result in an explosion. Dispose of batteries at your local battery recycling centre.

OPERATION....continued

WIFI SMARTPHONE AND SMART HOME INSTRUCTIONS

Your Kalora Nexus Electric Fireplace can be connected and fully operated using a WiFi Smartphone App, it can also be connected to either a Google Home or Amazon Alexia device for simple on/off operation commands.

Please scan the following QR code for detailed instructions on how to connect your Nexus Fireplace using the WiFi Smartphone App, Google Home or Amazon Alexia:



TEMPERATURE LIMITING CONTROL

This appliance is equipped with a temperature limiting control. Should the heater reach an unsafe temperature (100°C), the heater will automatically turn OFF.

To reset:

- 1 Turn the ON/OFF switch on the CONTROL PANEL to OFF.

- 2 Unplug the power cord from the outlet.

- 3 Inspect the appliance to make sure no vents are obstructed or blocked with dust or lint.. If so use a vacuum to clean these areas.

- 4 With the power switch in the OFF position, plug the power cord back into the outlet. Switch ON the power switch.

- 5 If the appliance switches off again then the appliance is faulty and must be returned to the original point of purchase.



NOTE:

When the heater is first turned on, a slight odor may be present. This is normal and should not occur again unless the heater is not used for a long period of time.

To improve operation, aim the remote control at the front of the fireplace. DO NOT press the buttons too quickly. Give the unit time to respond to each command.

CARE AND MAINTENANCE

CLEANING

NEVER immerse or spray with water. Doing so could result in electric shock, fire, or personal injury.

METAL:

Wipe using a soft cloth, slightly dampened with a citrus oil based product.

DO NOT use brass polish or household cleaners as these products will damage the metal trim.

GLASS:

Use a good quality glass cleaner sprayed onto a cloth or towel, clean the glass then dry thoroughly with paper towel or a lint-free cloth.

NEVER use abrasive cleaners directly on the glass surface.

VENTS:

Use a vacuum or duster to remove dust or debris from the vent inlet and outlet areas.

PLASTIC:

Wipe gently with a slightly damp cloth and a mild solution of soap and warm water.

NEVER use abrasive cleansers directly on the plastic surface.

WARRANTY

2 YEAR LIMITED WARRANTY

This limited warranty (Warranty) is given by Kalora Pty Ltd (ACN 142 881 141) (Kalora or we) to the original retail purchaser (You) of the Electric Fireplace to which this Warranty applies.

Our goods come with guarantees that cannot be excluded under the Australian Consumer Law. You are entitled to a replacement or refund for a major failure and for compensation for any other reasonably foreseeable loss or damage. You are also entitled to have the goods repaired or replaced if the goods fail to be of acceptable quality and the failure does not amount to a major failure.

The benefits that this Warranty provides are in addition to other rights and remedies available to you under the Australian Consumer Law. This Warranty does not limit those rights and remedies.

IMPORTANT: For this Warranty to apply, you must fully complete the online warranty registration form within 30 days after the original purchase. By completing this, you also agree that, to the extent permitted by law, our liability to You on any basis in relation to the Electric Fireplace (other than under the Australian Consumer Law) is limited to our obligations under this Warranty.

SCOPE OF WARRANTY

If:

- a defect in material or workmanship appears in the following parts within the corresponding warranty period after the date of the original purchase, such as to make the Electric Fireplace unfit for normal home use and;
- you comply with the requirements below regarding making a claim, then, subject to the exclusions below, we will (or will arrange to) replace or repair the relevant part or (at our option) replace the entire Electric Fireplace with the same or comparable model.

EXCLUSIONS

This Warranty does not apply:

- if the Electric Fireplace is not installed or operated to the specifications detailed in this manual;
- where the defect is not due to the original design or manufacture of the part (including where the appliance or part has been subject to accident, abuse, alteration, misuse or neglect or has been installed, altered, inspected, operated, cleaned or maintained negligently or not in accordance with applicable local laws, regulations and standards and the instructions and requirement included in this manual);
- if you are not a retail purchaser, or in the case of non domestic use (e.g. any commercial venue);

WARRANTY....continued

- to any accessories or optional parts;
- to noise caused by minor expansion, contraction or movement of parts;
- to any initial smell due to dust, paint or surfaces curing;
- to changes in surface finishes as a result of ordinary use (including interior and exterior colour changes or fingerprint marks) or any discolouration of glass;
- to any surface rust which may occur in transit, storage or use;
- to any defect caused, or likely to have been caused, by an unsuitable environment, including but not limited to:
 - Close proximity to beaches;
 - atmospheres containing chlorine or fluorine.

HOW TO MAKE A CLAIM

Any claim under this Warranty must be in writing to our mail or email address below. It must be sent within the applicable warranty period and must include:

- the model number of the Electric Fireplace;
- A copy of the receipt detailing the place, price and date of purchase; and
- reasonable details of the defect.

REGISTER YOUR PRODUCT



REGISTER BY MAIL

Please complete the attached warranty card within 30 days of installation and return to:

Kalora Pty Ltd
58 Access Way
Carrum Downs
Victoria, Australia, 3201

WARRANTY REGISTRATION CARD

MODEL NO:		SERIAL NO:	
PURCHASED BY:		PHONE:	
ADDRESS:			
EMAIL:		POSTCODE:	
PURCHASED FROM:		DATE:	
ADDRESS:			
INSTALLED BY:		DATE:	
INSTALLERS EMAIL:			
INSTALLERS NAME PRINT:		INSTALLERS SIGNATURE:	



REGISTER BY MAIL

Please complete this warranty card within 30 days of installation and return to:
Kalora Pty Ltd.
58 Access Way, Carrum Downs, Victoria, Australia, 3201.

Please keep your receipt as this will authenticate your warranty.

HEAD OFFICE

58 Access way,
Carrum Downs, Victoria,
Australia, 3201

+613 8579 5905
service@kalora.com.au
www.kalora.com.au



Kalora Pty Ltd
58 Access Way, Carrum Downs
Victoria 3201
Australia